

CAST IRON GATE VALVES-BS 5150

CLASS 125

SPECIFICATIONS

BOLTED BONNET, INSIDE SCREW & NON RISING STEM, FLANGED ENDS AS PER 4504 PN 16 / BS 1560 Sec.3.2 CI 150 / ANSI B16.1 CLASS 125-AS APPLICABLE

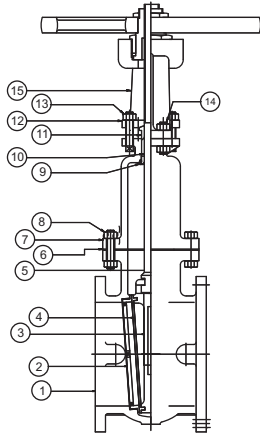

STANDARD MATERIAL COMBINATION

Part No.	QTY.	PART DESCRIPTION	MATERIALS	
			S.S. STEM, Cu-ALLOY FACED	S.S. TRIM
1	1	BODY	C.I. TO EN 1561 Gr. GJL200	C.I. TO EN 1561 Gr. GJL200
2	2	BODY SEAT RING	G.M TO EN 1982 Gr. CC491K	S.S TO BS 970 Gr. 410 S21/AISI410/ ASTM A182 Gr. F6a OR THEIR Eq.
3	2	WEDGE FACING RING	G.M. TO EN 1982 Gr. CC491K	S.S TO BS 970 Gr. 410 S21/ ASTM A182 Gr. F6a OR THEIR Eq.
4	1	WEDGE	C.I. TO EN 1561 Gr. GJL 200	C.I TO EN 1561 Gr. GJL200
5	1	STEM	S.S TO BS 970 Gr. 410 S21/ ASTM A182F6a/ASTM A276-410 OR THEIR Eq.	S.S TO BS 970 Gr. 410 S21/ ASTM A182F6a/ASTM A276-410 OR THEIR Eq.
6	1	GASKET	C.A.F TO BS 1832	C.A.F TO BS 1832
7	1	BONNET	C.I TO EN 1561 Gr. GJL200	C.I TO EN 1561 Gr. GJL200
8		BOLTS & NUTS	CARBON STEEL TO BS 916	CARBON STEEL TO BS 916
9	1	BACK SEAT BUSHING	G.M TO EN 1982 Gr. CC491K	S.S TO BS 970 Gr. 410 S21/ ASTM A182F6a/ASTM A276-410 OR THEIR Eq.
10	2	PIN FOR EYE BOLTS	CARBON STEEL (MIN.UTS 392 N/mm2)	CARBON STEEL (MIN.UTS 392N/mm2)
11	2	EYE BOLTS & NUTS	CARBON STEEL (MIN.UTS 392 N/mm2)	CARBON STEEL (MIN.UTS 392N/mm2)
12	1	PACKING	TO SUIT SERVICE CONDITIONS	TO SUIT SERVICE CONDITIONS
13	1	GLAND FLANGE	C.I TO EN 1561 Gr. GJL200	C.I TO EN 1561 Gr. GJL200
14	1	GLAND FOLLOWER	G.M TO EN 1982 Gr. CC491K	S.S TO BS 970 Gr. 410 S21/ ASTM A182F6a/ASTM A276-410 OR THEIR Eq.
15	1	YOKE SLEEVE	G.M TO EN 1982 Gr. CC491K	S.S TO BS 970 Gr. 410 S21/ ASTM A182F6a/ASTM A276-410 OR THEIR Eq.
16	1	YOKE SLEEVE RETAINING NUT	G.M TO EN 1982 Gr. CC491K	CARBON STEEL (MIN.TENSILE STRENGTH 392 N/mm2)/ AL. BRONZE TO EN 1982 Gr. CC331G/ M.I. TO IS 2108 BM 290
17	1	HAND WHEEL	C.I TO EN 1561 Gr. GJL200	C.I TO EN 1561 Gr. GJL200
18	1	HAND WHEEL RETAINING NUT	G.M TO EN 1982 Gr. CC491K	CARBON STEEL

PRESSURE/ TEMPERATURE RATINGS TO BS 5150

NOMINAL PRESSURE	MAX. PERMISSIBLE GAUGE WORKING PRESSURE 0C						
	-10 TO 120°C	150°C	180°C	200°C	220°C		
PN 10	10 bar	9.0 bar	8.4 bar	-	-		
PN 16	16 bar	14.4 bar	13.4 bar	12.8 bar	-		
CLASS RATING	SIZES	MAX. PERMISSIBLE GAUGE WORKING PRESSURE 0C					
		-10 TO 65°C	120°C	150°C	180°C	200°C	220°C
CLASS 125	≤300mm	13.8 bar	12.1 bar	11.4 bar	10.3 bar	9.8 bar	9.0 bar
	>300mm<450	10.3 bar	8.6 bar	7.6 bar	6.9 bar	-	-

NOTE: The above data is subject to change without notice.

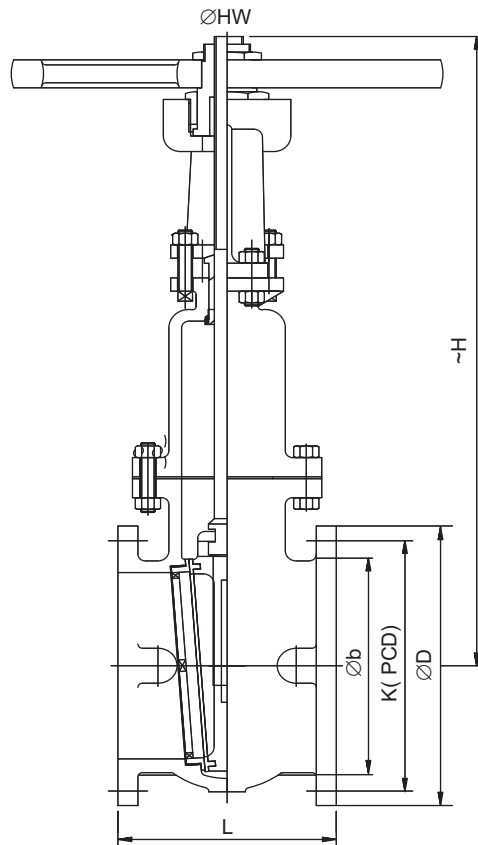

FIG. NO. : CI011

CATALOGUE FIG. NOS.

ITEM	SIZES	FIG. NO.	END DETAILS
CAST IRON GATE VALVE-EN 1171 CLASS 125 (S.S. STEM. Cu-ALLOY SEAT FACED)	≤12"	CI-011 FF	FLANGED ENDS TO ANSI B 16.1 CLASS 125 FF

DIMENSIONAL DATA

DN NPS	40 1 1/2	50 2	65 2 1/2	80 3	100 4	125 5	150 6	200 8	250 10	300 12	350 14	400 16	450 18	500 20	600 24	
L	165	178	190	203	229	254	267	292	330	356	381	406	432	457	508	
H (OPEN)	310	322	405	410	475	567	665	800	980	1130	1400	1525	1750	1880	2145	
HW	210	210	210	225	255	310	310	400	460	500	550	711	711	765	765	
Øb	38	51	65	80	102	127	152	203	254	305	356	406	457	508	609	
K(PCD)	98	121	140	152	191	216	241	299	362	432	476	540	578	635	749	
ØD	127	152	178	191	229	254	279	343	406	483	533	597	635	699	813	
Aprox.Wt. ^	12.82	23.35	22.85	34.9	56.45	72.7	92.1	137.3	222.7	297	479.6	669	875	1168	17411	
ITEM CODE NOS.	CLASS 125 (S.S STEM, Cu-ALLOY FACED)	CI 011 I	CI 011 J	CI 011 K	CI 011 L	CI 011 N	CI 011 O	CI 011 P	CI 011 R	CI 011 S	CI 011 T	CI 011 U	CI 011 V	CI 011 W	CI 011 X	CI 011 Y

TEST PRESSURES

NOMINAL PRESSURE ACCORDING TO PN OR CLASS DESIGNATION	SIZES	SHELL TEST (HYDROSTATIC)	SEAT TEST (HYDROSTATIC)	STANDARD NO.
PN 10	≤600mm	15 bar	11 bar	BS 6755 PART-1
PN 16	≤300mm	24 bar	17.6 bar	
CLASS 125	≤12"	20.7 bar	15.18 bar	
	≥12" ≤24"	15.45 bar	11.33 bar	

NOTE: The above data is subject to change without notice.

^ (WEIGHT GIVEN IN KGS)