

TRIM MATERIAL COMBINATION (ON REQUEST)		
Trim NO.	Seat ring face Part No.2	Disc Ring Face PartNo.3
1	F6a/13%Cr.	F6a/13%Cr.
2	F304	F304
5	STELLITE	STELLITE
8	STELLITE	F6a/13%Cr
9	MONEL	MONEL
10	F316	F316
13	ALLOY 20	ALLOY 20

OTHER TRIM COMBINATION OF API 602 CAN BE PROVIDED ON REQUEST.

STANDARD MATERIAL COMBINATION											
P.NO.	DESCRIPTION	Carbon Steel to ASTM		Alloy Steel to ASTM				Stainless Steel to ASTM			
		A105	A350LF2	A182F1	A182F11	A182F22	A182F9	A182F304	A182F316	A182F304L	A182F316L
1	BODY	A105	A350LF2	A182F1	A182F11	A182F22	A182F9	A182F304	A182F316	A182F304L	A182F316L
4	GASKET	Stainless steel + Graphoil									
5	COVER	A105	A350 LF2	A182F1	A182F11	A182F22	A182F9	A182F304	A182F316	A182F304L	A182F316L
6	STUDS	A193 B7	A320 L7	A193 B7	A193 B16	A193B16	A193B16	A193 B8	A193 B8	A193 B8	A193 B8
7	NUTS	A194 2H	A194 Gr.4	A194 2H	A194 Gr.4	A194 Gr.4	A194 Gr.8	A194 Gr.8	A194 Gr.8	A194 Gr.8	A194 Gr.8

DIMENSIONAL DATA CLASS-600 (FLANGED ENDS)											
DN	NPS	L(RF)	φD	T	K(PCD)	n	φd	H	Aprox.Wt. ^		
15	½	165	95.5	14.2	66.5	4	15.7	60	3.630		
20	¾	190	117.5	15.8	82.5	4	19.1	78	6.79		
25	1	216	124	17.5	88.9	4	19.1	90	9.06		
32	1 ¼	229	133.5	20.6	98.5	4	19.1	97	---		
40	1 ½	241	155.5	22.4	114.3	4	22.3	97	16.400		
50	2	292	165.1	25.4	127	8	19.1	120	18.540		

NOTE: The above data is subject to change without notice.

(^WEIGHT GIVEN IN KGS)

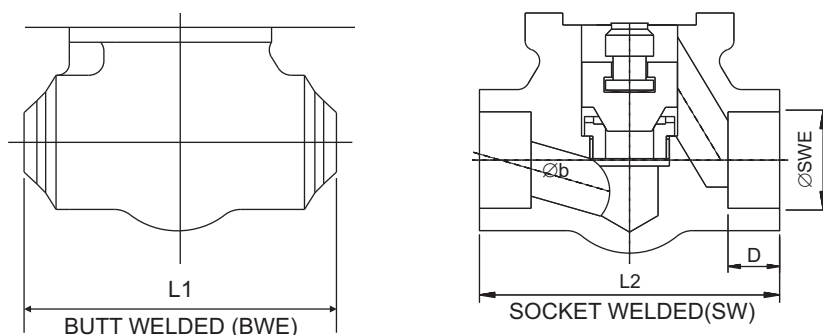

DIMENSIONAL DATA CLASS -800

DN	NPS	φb	L1(BWE)	L2(SWE)	H	φSWE		D	Aprox. Wt. [^]
						BS 3799	ASME B16.11		
15	1/2	9.5	80	80	55	+0.3 21.8 -0.0	22.2 21.8	11	1.15
20	3/4	12.5	88	88	60	+0.3 27.4 -0.0	27.6 27.2	14	1.450
25	1	18	100	100	78	+0.3 34.1 -0.0	34.3 33.9	14	2.2
40	1 1/2	30	145	145	97	+0.3 49 -0.0	49.2 48.8	14	5.4
50	2	35	170	170	120	+0.3 61 -0.0	61.7 61.2	17	7

DIMENSIONAL DATA CLASS -1500

DN	NPS	φb	L1(BWE)	L2(SWE)	H	φSWE		D	Aprox. Wt. [^]
						BS 3799	ASME B16.11		
15	1/2	12	100	100	78	+0.3 21.8 -0.0	22.2 21.8	11	1.450
20	3/4	15	124	124	90	+0.3 27.4 -0.0	27.6 27.2	14	2.200
25	1	19	145	104	97	+0.3 34.1 -0.0	34.3 33.9	14	3.915
32	1 1/4	31	170	170	120	+0.3 42.9 -0.0	43.1 42.7	14	5.400
40	1 1/2	31	170	170	120	+0.3 49 -0.0	49.2 48.8	14	7

DIMENSIONAL DATA CLASS -2500

DN	NPS	φb	L1(BWE)	L2(SWE)	H	φSWE		D	Aprox. Wt. [^]
						BS 3799	ASME B16.11		
15	1/2	11	130	130	75	+0.3 21.8 -0.0	22.2 21.8	11	
20	3/4	14	130	130	75	+0.3 27.4 -0.0	27.6 27.2	14	
25	1	19	130	130	75	+0.3 34.1 -0.0	34.3 33.9	1	

TEST PRESSURES

CLASS	SHELL TEST (HYDROSTATIC)		SEAT TEST			
			HYDROSTATIC		PNUEMATIC	
600	150 Bar g	2174 Psi g	110 Bar g	1595 Psi g	N.A.	N.A.
800	207 Bar g	3002 Psi g	152 Bar g	2204 Psi g	N.A.	N.A.
1500	384 Bar g	5568 Psi g	281 Bar g	4075 Psi g	N.A.	N.A.
2500	639 Bar g	9270 Psi g	468 Bar g	6790 Psi g	N.A.	N.A.

NOTE: The above data is subject to change without notice.

([^]WEIGHT GIVEN IN KGS)